

edbak



Catalogue 2026

**Professional Mounting Systems
for Every Space**



Content

OUR CORE VALUES	6
ABOUT US	8
CERTIFICATES	9
SCREEN & MONITOR MOUNTS	10
DESKTOP MOUNTS	16
TROLLEYS & STANDS	20
ACCESSORIES FOR TROLLEYS & STANDS	26
MENU BOARD	30
VIDEO WALLS	34
UNIVERSAL LED STRUCTURE	38
PROJECTOR MOUNTS	42
KIOSKS & ENCLOSURES	46
RETAIL MOUNTS	52
WINDOW DISPLAY MOUNTS	56

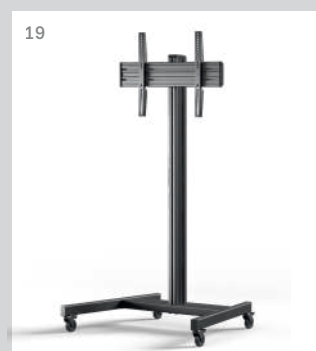
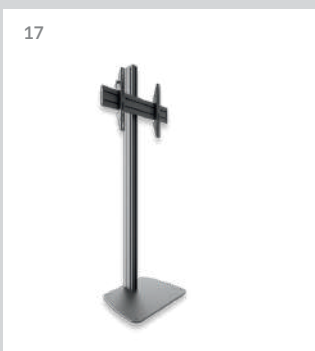
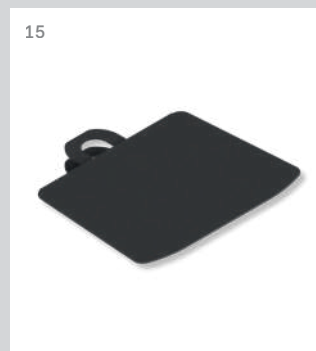
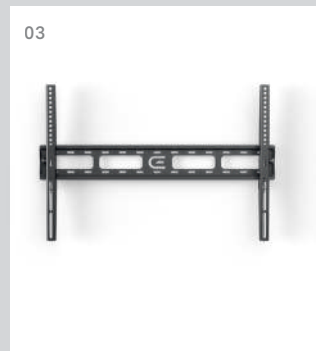

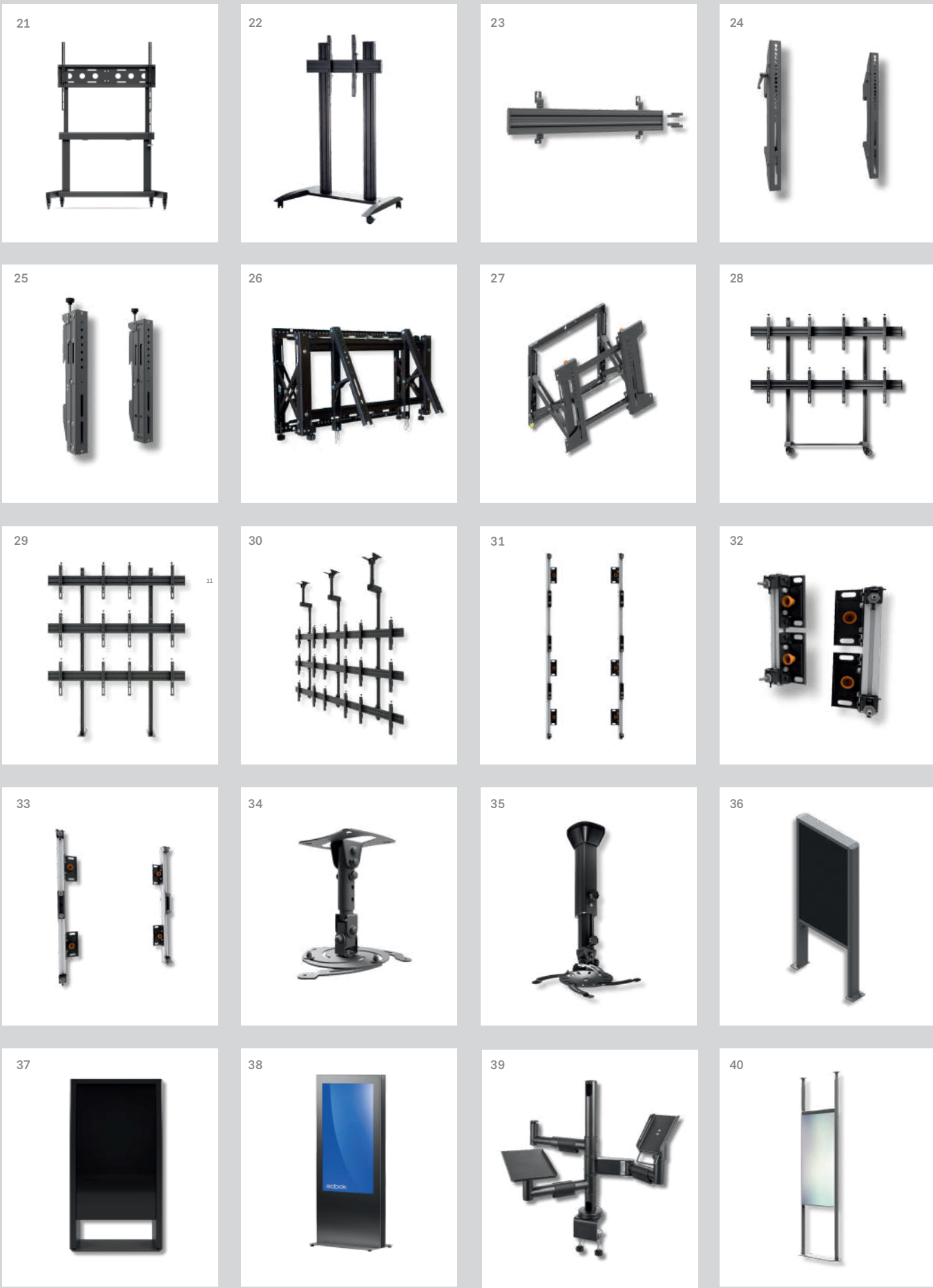

Our Core Values

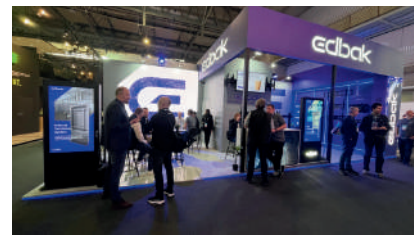

Partnership

We respect every employee and customer, listening and acting as partners. Working together in synergy, we achieve strong leadership and a dynamically recognisable brand.

Creativity & Innovation

We create useful, ethical, and modern products that connect people with technology, striving for high- -standard production and innovative solutions that support the future.

Professionalism

We pursue goals with respect and adherence to rules, ensuring everyone feels indispensable.
This makes EDBAK a reliable partner and provider of excellent solutions.

Engagement & Responsibility

Employees take ownership of their actions and participate proactively in decisions, driving commitment, motivation, and the genuine development of the company.

Improvement & Development

For 31 years we have refined our craft, trained employees, optimised processes, and invested in technology, growing locally and gaining global recognition.

Markets

Serving corporations, public institutions, government organizations, small businesses, and professional AV integrators, EDBAK delivers comprehensive mounting and structural solutions tailored to diverse commercial and public environments.

From high-traffic retail spaces and corporate headquarters to educational facilities, healthcare centers, control rooms, hospitality venues, and transportation hubs – our systems are engineered to perform reliably wherever displays need to inform, engage, or impress.

We design and manufacture versatile solutions including customer-friendly video walls, intuitive wayfinding kiosks, lobby information boards, digital signage structures, freestanding totems, ceiling and wall mounts, mobile trolleys, and modular LED systems. Whether supporting a single screen in a meeting room or a large-scale LED installation in a public venue, EDBAK products are built to adapt.

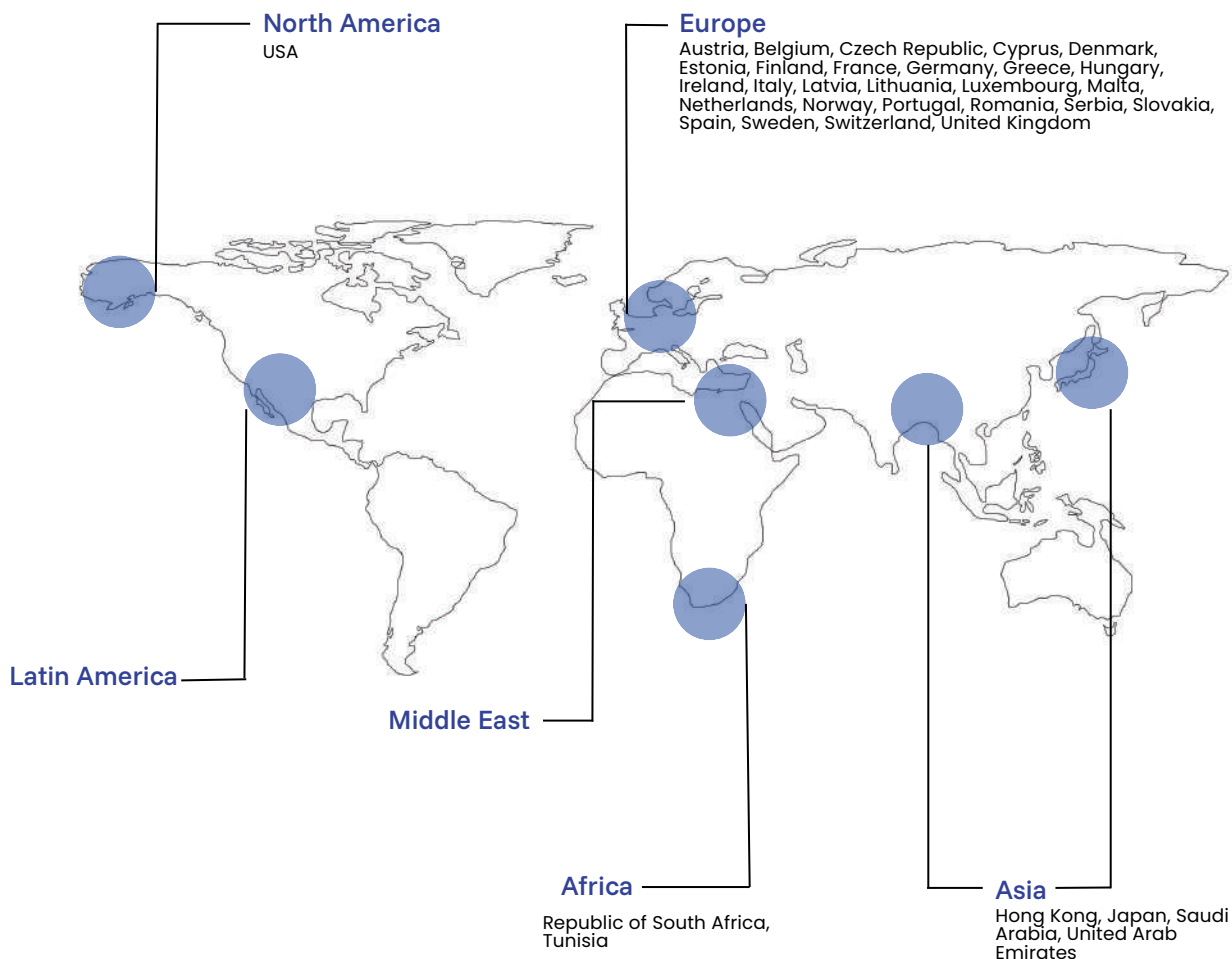

About



EDBAK is a Polish, family-owned manufacturer of professional mounting systems. Founded in 1992, the company is now one of Europe's leading manufacturers of AV solutions, offering display mounts, wall brackets, conference trolleys, stands, desktop monitor mounts, dedicated LED systems, video wall mounts, and information kiosks.

All products are designed and manufactured in Poland. With its own machine park and in-house R&D department, EDBAK combines engineering expertise, production flexibility, and full quality control. Alongside standard solutions, the company also develops products tailored to the needs of end customers, business partners, and system integrators.

EDBAK delivers safe, durable, easy-to-install, and ergonomically designed AV mounting solutions for professional applications.

Certificates

ISO 9001 - Quality Management

ISO 14001 - Environmental Management

ISO 45001 - Occupational Health and Safety Management

AQAP 2110 - NATO Quality Assurance Requirements

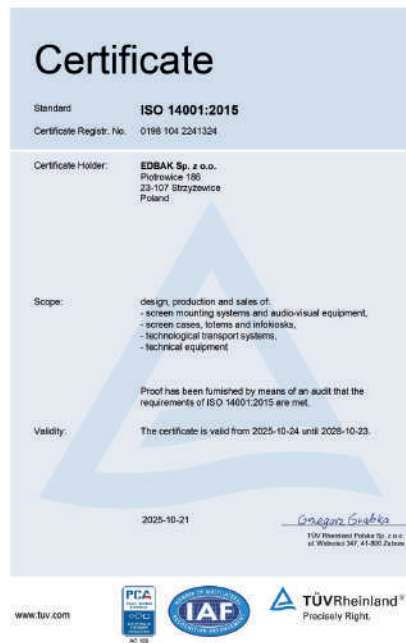
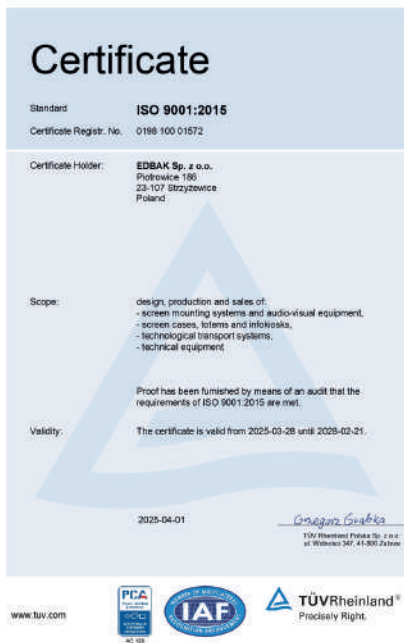

AVIXA Silver Member

Screen & Monitor Mounts

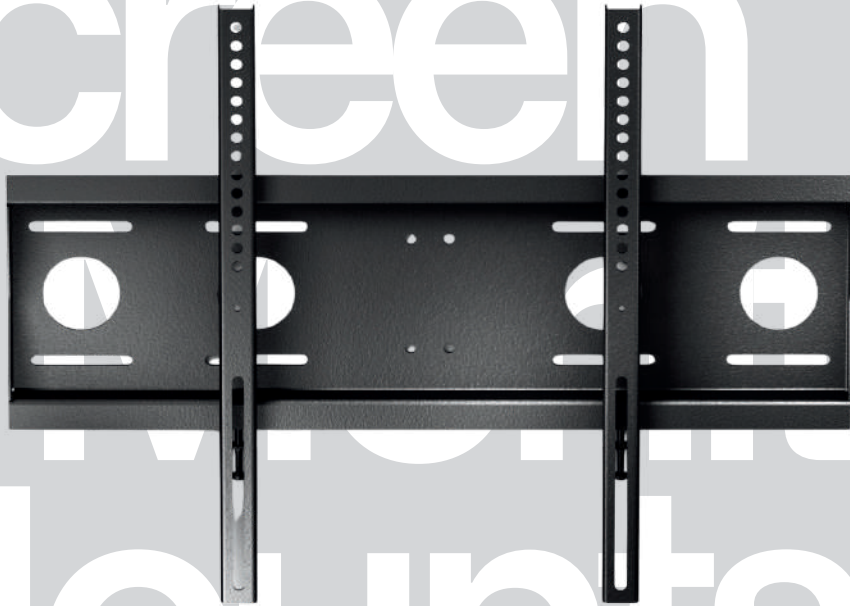

Screen & Monitor Mounts

Our Screen & Monitor Mounts category offers a comprehensive range of professional mounting solutions designed for commercial, corporate, educational, retail, and public environments.

Engineered for strength, precision, and long-term reliability, these systems ensure secure and stable support for displays and monitors of various sizes and weights.

The portfolio includes fixed, tilt, swivel, ceiling, and desk-mounted solutions compatible with a wide range of VESA standards. Each product is designed to enable fast installation, easy adjustment, and clean cable management ensuring both functional efficiency and aesthetic integration into modern interiors.



ELWM60 Wall mount with manual height adjustment for screens 55" – 86"

The ELWM60 is a professional wall mount with manual height adjustment designed for 55"–86" displays. Developed for conference rooms, educational environments, and modern office spaces, it allows convenient screen positioning tailored to different users and applications.

- 1. Manual height adjustment for flexible screen positioning
- 2. Stable and durable steel construction
- 3. Fast and straightforward installation
- 4. User-friendly adjustment mechanism
- 5. Ideal for conference rooms, offices, and educational environments
- 6. RoHS compliant



min. 100x100
max. 600x400



40 - 60 kg



55"-86"



PWB1 Universal fixed wall mount for screens 40"- 75"

PWB1 is a universal flat wall mount designed for secure and stable installation of 40"–75" displays. Its slim, minimalist design ensures a clean and modern look, while the robust steel construction provides reliable support in professional environments.

1. Ultra-slim, flat wall mounting design
2. Wide VESA compatibility (100×100 to 600×400)
3. Screen protection against falling
4. Lateral screen adjustment after installation
5. Mounting screws included
6. Compatible with concrete, brick, plaster, and wooden walls
7. Simple and quick installation

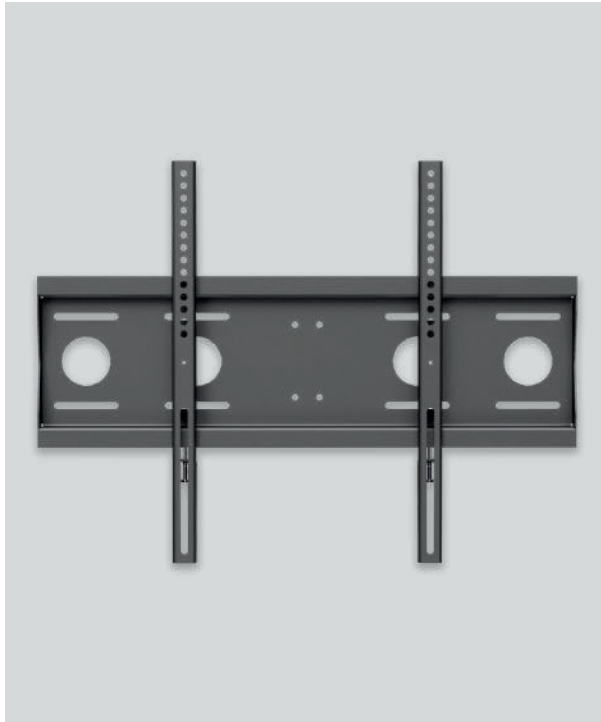
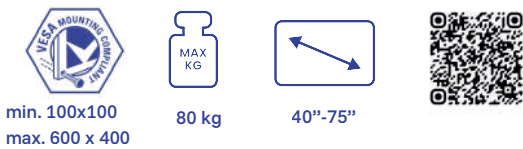

FSM4040-F Universal Flat Wall Mount for 32"-75" screens

FSM4040-F is a robust and practical flat wall mount designed for secure installation of screens ranging from 32 to 75 inches. Its slim profile and clean, modern design make it an ideal solution for conference rooms, offices, waiting areas, and other professional environments.

1. Designed for screens from 32" to 75"
2. Maximum load capacity up to 30 kg
3. Durable steel construction for professional use
4. Post-installation leveling adjustment
5. VESA compatibility: 100×100 to 400×400
6. Suitable for installation on concrete, brick, and wooden walls
7. Slim design for minimal distance from the wall
8. Simple and fast installation



TWB1 Universal fixed wall mount for screens 50" - 86"



TWB1 is a heavy-duty flat wall mount engineered for secure and reliable installation of large-format screens from 50 to 85 inches. Designed for demanding commercial and public environments, it combines structural strength with a clean, professional finish.

1. Durable steel construction for heavy-duty applications
2. Screen protection against accidental dislodging
3. Lateral screen adjustment after mounting
4. VESA compatibility from 100×100 up to 800×400
5. Suitable for installation on brick, concrete, plaster, and wooden walls
6. Simple, fast, and secure installation
7. Compatible as a standalone mount or structural component



min. 100x100
max. 800 x 400



80 kg

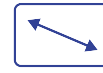

50"-85"



PWB2 Universal tilting wall mount for screens 40" - 75"

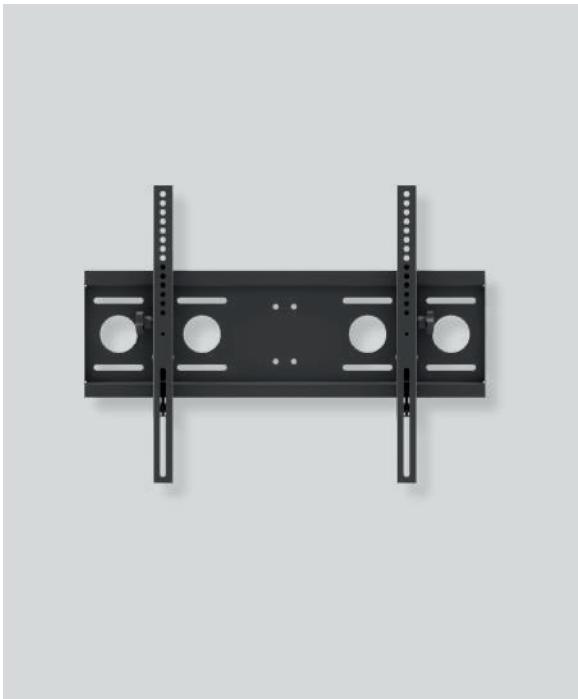

PWB2 is a robust and reliable tilting wall mount designed for secure installation of medium and large-format screens from 40 to 75 inches. Engineered for strength and stability, it combines high load capacity with a slim, minimalist design suitable for professional and public environments.

1. Maximum load capacity up to 80 kg
2. Durable steel construction
3. Anti-theft protection against accidental screen removal
4. Tilting function for improved viewing comfort
5. Lateral screen adjustment after installation
6. Minimalist, space-saving design
7. Suitable for installation on brick, concrete, plasterboard, and wooden walls
8. Quick and secure installation



min. 100x100
max. 600x400



80 kg



40"-75"



VSM653 Double swivel wall arm for 49" -65" screens

VSM653 is a professional double swing arm wall mount designed for screens ranging from 49 to 65 inches. Engineered for maximum flexibility and user comfort, it allows smooth adjustment of screen position to adapt to changing room layouts and viewing requirements.

1. Maximum load capacity up to 36 kg
2. Durable aluminum arm construction
3. Double swing arm design for extended reach
4. Full 90° / 90° left-right screen rotation
5. Forward tilt adjustment up to +11°
6. Integrated cable management system
7. Modern, aesthetic finish



min. 100x100
max. 600 x 400



36 kg



49"-65"



GD18 Swivel wall arm for 10" - 29" screens

GD18 is a compact and versatile swing arm wall mount designed for small screens ranging from 10 to 29 inches. Its simple yet durable construction allows for secure installation on walls of various structures, making it suitable for both residential and professional applications.

1. Maximum load capacity up to 10 kg
2. Durable and stable construction
3. 3-axis adjustment for precise positioning
4. Full 360° vertical-horizontal screen rotation
5. Up to 130° left-right rotation
6. Forward tilt adjustment up to +50°
7. Integrated cable management
8. Suitable for portrait orientation



min. 75 x 75
max. 100x100



30 kg



10"- 29"





Desktop Mounts

Desktop Mounts

Desktop Mounts are ergonomic solutions designed to improve monitor positioning and workspace comfort. They provide stable support with flexible adjustment options, including tilt, swivel, height, and rotation.

Ideal for offices and professional environments, these mounts enhance productivity while maintaining a clean and organized desk setup.

SV01 Desktop Mount for 10"-29" screens



SV01 is a versatile desktop mount designed for screens from 10 to 29 inches, providing ergonomic support in both office and home environments. Its solid construction and adjustable design ensure stable monitor positioning while improving workspace comfort and efficiency.

1. Height adjustment for ergonomic positioning
2. Forward tilt range: -50° to $+50^{\circ}$
3. Full 360° screen rotation
4. Horizontal swivel adjustment
5. Two mounting options included
6. Universal VESA compatibility: $75 \times 75 - 100 \times 100$
7. Integrated cable management
8. 5-year limited warranty



min. 75×75
max. 100×100



10 kg



$10'' - 29''$



$-50^{\circ}/+50^{\circ}$



SV03 desk mount with double arm for 10" - 29" screens



SV03 is a functional desktop mount with a double arm design, created for screens from 10 to 29 inches. It is an ideal solution for users who require extended flexibility and ergonomic comfort in office, home, and professional work environments.

1. Double arm construction for extended flexibility
2. Full height adjustment
3. Forward tilt range: -50° to $+50^{\circ}$
4. 360° screen rotation
5. 360° arm rotation
6. Two desk mounting options included
7. Integrated cable management
8. Modern, minimalist design



min. 75×75
max. 100×100



10 kg



$10'' - 29''$



$-50^{\circ}/+50^{\circ}$



SV06 Desk mount with arm for two 19" - 32" monitors

SV06 is a professional desktop mount designed for the installation of two monitors. Engineered for users who require advanced ergonomics and maximum flexibility, it provides independent adjustment of each screen, ensuring optimal comfort and productivity.

1. Designed for two 19–32" monitors
2. Independent adjustment of both screens
3. Full height adjustment
4. Forward tilt range: -50° to $+50^{\circ}$
5. Three rotation axes on each arm
6. Two desk mounting options included (clamp and desk-through)
7. Integrated cable management



min. 75 x 75
max. 100 x 100



20 kg



19" - 32"



$-50^{\circ}/+50^{\circ}$



SV07 Desk mount for four 19" - 27" monitors

SV07 is a professional desktop mount designed for the installation of four monitors, providing an efficient and ergonomic solution for advanced workstation setups. It is particularly suited for environments where continuous screen monitoring is required, such as control rooms, monitoring centres, and professional office workstations.

1. Independent adjustment of each monitor
2. Forward tilt range: -50° to $+50^{\circ}$
3. Full 360° left-right screen rotation
4. Two desk mounting options included
5. Integrated cable management system
6. Modern, functional design
7. Quick and easy installation



min. 75 x 75
max. 100x100



40 kg



19" - 27"



$-50^{\circ}/+50^{\circ}$



Trolleys & Stands



Trolleys & Stands

Trolleys and stands deliver maximum flexibility wherever displays need to move, adapt, or work in changing spaces. Designed for corporate meeting rooms, education, retail, and events, these mobile and freestanding solutions combine stability with everyday usability. From compact presentation stands to heavy-duty trolleys for large screens, the range supports safe handling, clean cable management, and quick setup.

Many designs offer height adjustment, accessory integration (shelves, camera trays, media boxes), and robust locking casters for secure positioning. Built for professional environments, EDBAK trolleys and stands provide a reliable platform for digital signage, videoconferencing, training, and live presentations wherever you need the screen to be. Ideal for offices and professional environments, these mounts enhance productivity while maintaining a clean and organized desk setup.

MWF200 Electric Height Adjustment Stand/Wall Mounted for 55"-98" screens

MWF200 is a professional wall/floor mounted stand with electric height adjustment, engineered for large displays from 55" to 98". The dual mounting points (wall and floor) provide excellent stability, while smooth powered movement makes it easy to raise or lower the screen for different users and use cases. It's an ideal solution for interactive touch displays in education and corporate environments, offering quick installation and wide VESA compatibility.

1. Electric height adjustment for effortless positioning
2. Adjustment range up to 650 mm
3. Wall & floor mounted design for maximum stability
4. Ideal for interactive touchscreen monitors (education & corporate)
5. Quick and easy monitor installation on the mounting arms
6. Colour: Black



min. 100x100
max. 800 x 600



80 kg



55" - 95"



TRE100 Conference cart for 42"-75" monitors

TRE100 is a professional videoconferencing trolley for 42"-75" displays. Its stable aluminium-and-steel frame with lockable, non-marking casters makes it easy to move and secure in any meeting or presentation space. It supports portrait or landscape mounting, offers smooth height adjustment, and includes integrated cable management for a clean finish. Optional shelves can be fitted to the column for a laptop or camera.

1. Stable aluminium & steel construction (high-end finish)
2. Portrait or landscape screen installation
3. Smooth screen height adjustment
4. Non-marking braked casters (easy to move, safe positioning)
5. Integrated cable management for tidy installation
6. Shelf-ready column (accessories can be fitted directly)
7. Fast, simple installation
8. Colour: Black



min. 100 x 100
max. 600 x 400



70 kg



42" - 75"



TRE200 Videoconferencing trolley for 75"- 105" monitors

The TRE200 is a premium mobile videoconferencing trolley for 75"-105" displays. A rigid aluminium frame, smooth height adjustment, cable management, optional AV shelves, and braked non-marking castors ensure a stable, tidy, and easy-to-move setup.

1. Stable, durable aluminium construction with high-end finish
2. Horizontal or vertical screen installation
3. Smooth screen height adjustment
4. Shelves mount directly to the supporting column (for camera/laptop/AV)

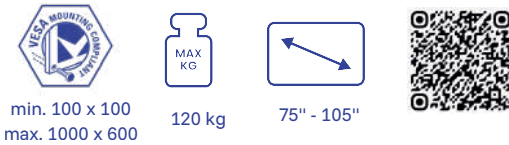

MTR200 Electric Height Adjustment Trolley for 55"- 98" screens

The MTR200 is a robust electric height-adjustment trolley for 55"-98" screens. With a wired control panel and up to 650 mm lift range, it enables quick, effortless positioning of interactive and large-format displays in education and corporate environments.

1. Electric height adjustment (up to 650 mm range)
2. Wired control panel
3. Ideal for interactive touchscreen monitors
4. Quick and easy installation on mounting arms

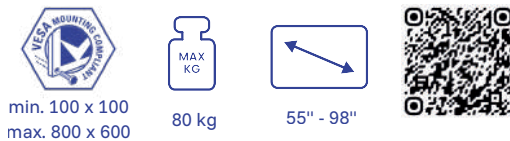

STDV100 Stand for screen 40" - 75"

The STDV00 is a universal floor stand for 40"-75" screens, created for elegant and safe display presentation in professional interiors. It features full height adjustment, a stable base with optional floor anchoring, integrated cable management, and forward tilt up to +11° for better viewing.

1. Full height adjustment
2. Stable base, optional floor fastening (anchors)
3. Integrated cable management

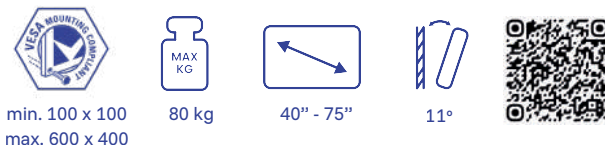

TRV Series – Flexible Videoconferencing Trolleys for Modern Collaboration Spaces

TRV Series is a range of videoconferencing trolleys designed for modern meeting spaces, collaboration areas, and presentation environments. Combining mobility, durable aluminium construction, intuitive screen adjustment, and integrated cable management, it provides a clean, flexible, and professional solution for everyday AV use. Suitable for single or dual screen configurations, the series supports comfortable communication, efficient presentations, and a tidy installation in offices, conference rooms, educational facilities, and public spaces.



TRV100 Videoconferencing trolley for 42" - 75" screens

The TRV100 is a mobile videoconferencing trolley designed for conference rooms, offices, and educational spaces. Its stable aluminium structure, smooth height adjustment, and integrated cable management ensure a clean, practical, and professional AV setup.

1. Modern design with high-quality finish
2. Stable and durable aluminium structure
3. Supports horizontal or vertical screen installation
4. Smooth and precise screen height adjustment



min. 100x100
max. 600x400



70 kg



42"-75"



0-11°



LANDSCAPE
OR PORTRAIT



TRV200 Videoconferencing trolley for 75" - 86" screens

The TRV200 is a professional mobile trolley designed for videoconferencing, presentations, and digital signage applications. Its stable aluminium construction, modern design, and smooth screen height adjustment ensure comfortable use in conference rooms, offices, hospitality areas, and educational environments.

1. Suitable for videoconferencing and presentation applications
2. Stable and durable aluminium construction
3. Smooth screen height adjustment
4. Shelves can be fitted directly to the supporting columns



min. 100 x 100
max. 900 x 600



120 kg



75" - 86"



0-11°



TRV300 Videoconferencing trolley for two 42" - 55" screens

TRV300 is a mobile videoconferencing trolley designed for dual-screen setups in professional meeting and presentation environments. Its stable aluminium structure, intuitive height adjustment, and integrated cable management provide a clean, functional, and reliable AV solution.

1. Designed for two 42"-55" screens
2. Supports horizontal or vertical screen installation
3. Integrated cable management system



min. 100 x 100
max. 600 x 400



120 kg



42" - 55"



11°



Accessories for Trolleys & Stands



Accessories for Trolleys & Stands

Expand the functionality of your trolley or stand with dedicated accessories designed for professional AV setups. From camera and laptop shelves to cable management and mounting add-ons, these components help create clean, ergonomic, and user-friendly installations in meeting rooms, education, and public spaces. Built to match EDBAK structures, they enable fast integration, improved usability, and a consistent look across projects.

CHV5 Camera shelf for TRV series carts



The CHV5 camera holder is a dedicated accessory for EDBAK TRV series trolleys, created to complete professional videoconferencing setups. Mounted on top of the structure, it positions the camera securely and ergonomically for an optimal recording angle and a clean, integrated look.

1. Designed for EDBAK TRV series mobile trolleys
2. Secure mounting for most videoconferencing cameras
3. Stable, rigid steel construction
4. Clean integration with the trolley design
5. Ideal for conference rooms, offices, and educational environments



10 kg



65" - 75"



CHV4 Camera shelf for videoconferencing trolleys

The CHV4 videoconferencing camera holder is a compact accessory for EDBAK TRV trolleys (TRV100 / TRV300), designed to mount a camera securely above the display. It provides a stable, ergonomic camera position for clear framing in meeting rooms and collaboration spaces, while keeping the installation clean and professional.

1. Compatible with EDBAK TRV100 and TRV300 trolleys
2. For 40"-55" screen setups
3. Secure top-mounted camera position for optimal framing
4. Rigid steel construction, clean integrated design



2 kg



40"-55"

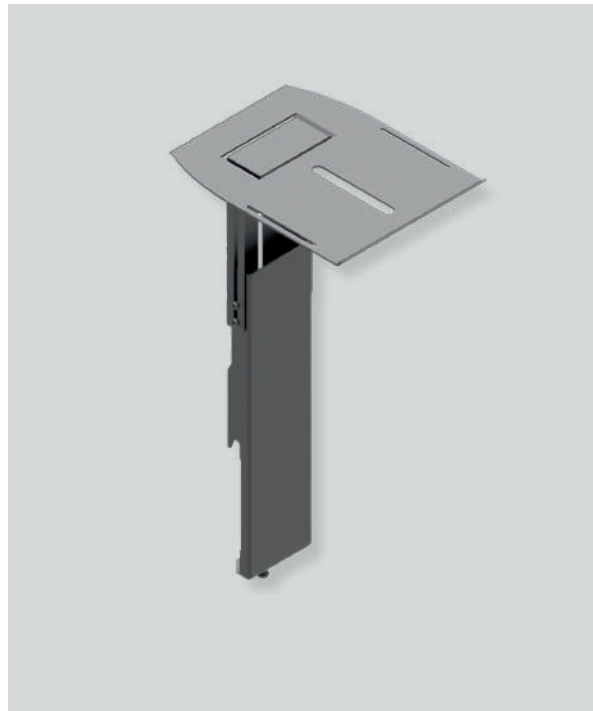

TRSU1 Universal metal shelf for TR, TRV, STD, STDV

TRSU1 is a universal metal shelf designed for selected EDBAK trolleys and stands, including TR, TRV, STD, and STDV series. Made of durable black powder-coated steel, it provides practical additional space for AV equipment, set-top boxes, laptops, and accessories.

1. Universal metal shelf for TR, TRV, STD, and STDV series
2. Provides additional space for AV equipment, laptops, and accessories
3. Durable steel construction with black powder-coated finish
4. Quick and easy installation
5. Clean integration with compatible trolleys and stands



2 kg



Menu Board



Menu Board

Menu Boards are professional mounting solutions for digital menu displays in quick-service restaurants, cafés, retail counters, and ordering zones. Designed for clear visibility and a clean, branded look, they enable secure installation of one or multiple screens, with tidy cable routing and robust construction for everyday operation. Ideal for price lists, promotions, and dynamic content that needs to stay readable and consistent in high-traffic customer areas.

VWM.ARMS – Arms for Modular Menu Board Mount

VWM.ARMS are sturdy mounting arms developed for modular menu board systems, ensuring secure and precise display installation within WMB structures. Made from durable steel, they provide stable support and clean alignment for professional digital signage in retail and QSR environments.

1. Designed for modular menu board systems (WMB)
2. Secure, stable mounting for professional displays
3. Durable steel construction with black finish
4. Slim, compact design for discreet installations



VWMPOP.ARMS – Pop-Out Arms for Modular Menu Board Mounts

VWMPOP.ARMS are robust pop-out mounting arms for modular menu board installations, enabling easy front access to displays for fast service and maintenance. The pop-out mechanism lets screens be pulled forward to reach cables and rear connections, making it ideal for QSR, retail, and high-traffic digital signage environments.

1. Pop-out function for convenient front access and maintenance
2. Designed for modular menu board systems
3. Smooth pull-forward mechanism for rear cable access
4. Compact design for clean, discreet installations



TRV.ADAPTER

TRV.ADAPTER is an arm extension accessory designed to expand compatibility of EDBAK mounting systems with large-format displays. It provides a secure, rigid extension for mounting arms, enabling installation of 70"-95" screens while maintaining stability and a clean, professional finish.

1. Arm extension accessory for EDBAK mounts
2. Increases mounting arm reach/compatibility for large displays
3. Durable steel construction with black finish
4. Quick integration with compatible EDBAK systems

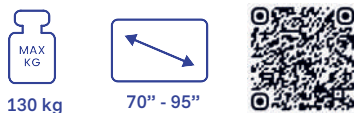

MBVP1500 Ceiling Mount for Modular Menu Boards

MBVP1500 is a robust ceiling mount designed for modular menu board installations. As part of the WMB system, it enables clean suspended setups with the required drop length while keeping height-adjustment mechanisms out of sight. Built from durable steel, it delivers a stable, secure, and professional finish for digital signage environments.

1. Ceiling mount for modular menu board systems
2. Compatible with WMB series components
3. Suspended installation with customizable drop length (no visible height adjustment)
4. Strong, stable steel construction with black finish
5. Ideal for professional AV and digital signage applications



VWMB SERIES Modular Menu Board Mount from 700 to 2200 mm

The VWMB Series is a modular menu board mounting system that enables flexible multi-screen configurations for retail and QSR installations. With adjustable lengths from 700 to 2200 mm and dedicated connectors, it allows fast assembly of custom layouts without cutting—delivering a clean, professional finish.

Length (mm)	Dimension (WxHxD) (mm)	Weight (kg)
700	720x300x56,1	4
970	990x300x56,1	4,8
1100	1120x300x56,1	5,2
1940	1960x300x56,1	8,4
2200	2220x300x56,1	9,25

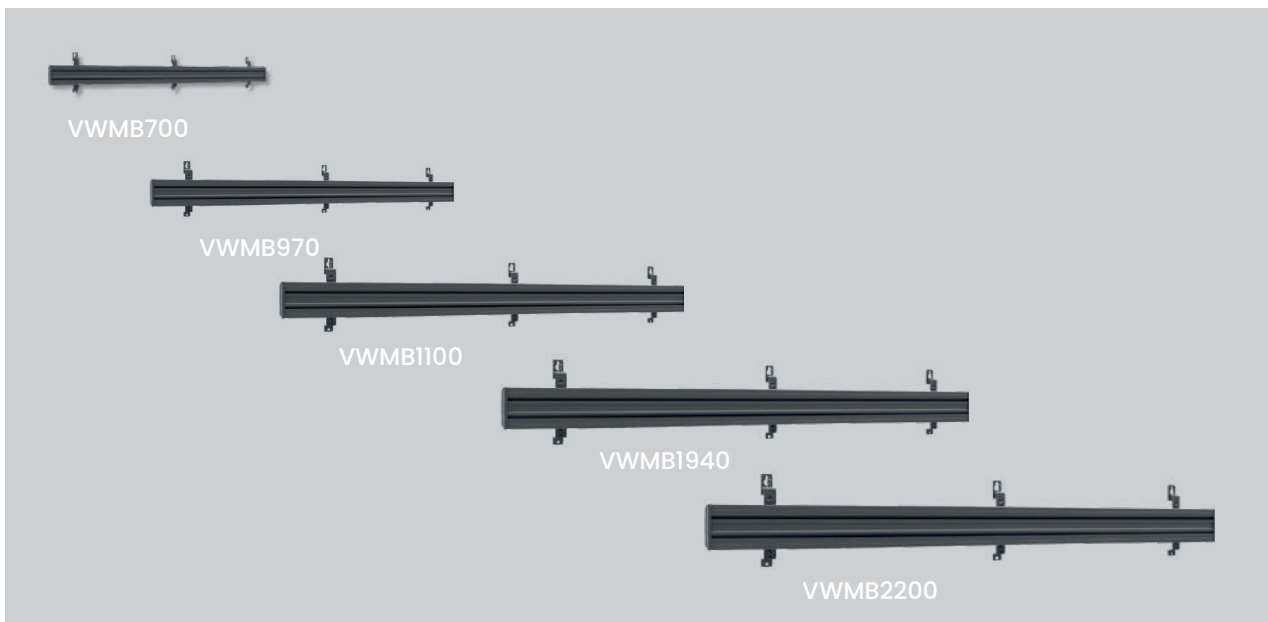



Video Walls

Video Walls are professional mounting and structural systems for building seamless multi-screen display arrays in control rooms, corporate lobbies, retail spaces, transportation hubs, and broadcast environments.

Designed for precision alignment, safe load distribution, and clean integration, EDBAK video wall solutions support fast installation and reliable long-term operation.

The portfolio covers mobile and fixed configurations, including pop-out service access and dedicated ceiling or floor-to-ceiling structures so you can choose the right format for every space and maintenance requirement.

VWTA3347-L – Mobile modular video wall structure, 3×3 configuration, for 42"- 49" screens

VWTA3347-L is a modular 3×3 mobile video wall trolley for 42"–47" landscape screens. A durable aluminium frame with braked castors ensures stable mobility, while micro-adjustment, cable management, and standard PC/mini PC mounts deliver precise alignment and a clean setup.

1. Independent 8-point micro-adjustment for seamless alignment
2. Durable aluminium frame, high-end finish
3. Braked castors for safe mobility
4. Screen security against accidental/unauthorised removal

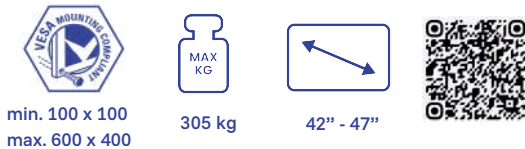

VWPOP95-P – Pop-out video wall mount for 70" – 98" screens

VWPOP95-P is a professional pop-out video wall mount with quick release, designed for 70"–95" screens in portrait orientation. The open design provides easy access to cabling, while independent micro-adjustment ensures precise alignment. A lock mechanism prevents uncontrolled opening, making it a safe and service-friendly solution for large-format video walls.

1. Independent 8-point tool-less micro-adjustment for perfect alignment
2. Pop-out mechanism for fast service access to rear connections
3. Lock to prevent uncontrolled opening

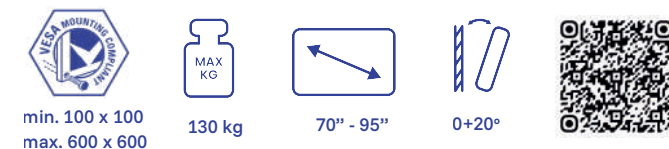

VWSA3357-L Floor mount video wall structure, modular 3×3, for 50"- 57" screens

VWSA3357-L is a modular 3×3 bolt-down video wall stand for 50"–57" landscape screens, designed for permanent installations in high-traffic spaces. Anchored to the floor for maximum stability, it offers precise 8-point micro-adjustment for seamless alignment, integrated cable management, and anti-theft protection for a clean and secure video wall setup.

1. Floor-anchored for maximum stability table base
2. Independent 8-point micro-adjustment (tool-less) for perfect alignment
3. Security screws against accidental/unauthorised screen removal

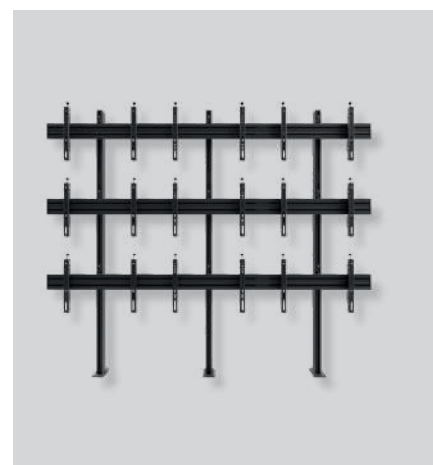

VWFA3347-L Floor-to-ceiling video wall structure, modular 3x3, for 42" - 49" screens

VWFA3347-L is a modular 3x3 floor-to-ceiling bolt-down video wall mount for 42"-47" landscape screens. Designed for permanent installations, it delivers maximum stability by fixing the structure to both floor and ceiling. Independent 8-point micro-adjustment ensures seamless screen alignment, while integrated cable management and security screws keep the installation clean and protected.

1. Fixed to floor and ceiling for maximum rigidity
2. Independent 8-point tool-less micro-adjustment for precise alignment
3. Security screws against accidental/unauthorised screen removal
4. Aluminium screen-carrying plates for durability



min. 100 x 100
max. 600 x 400



330 kg



42" - 47"

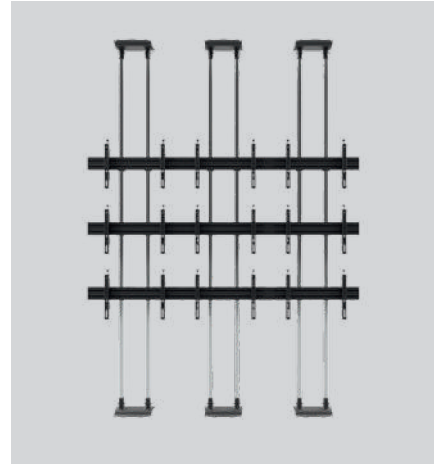

VWCA3347-L ceiling mount video wall structure, modular 3x3, for 42" - 47" screens

VWCA3347-L is a modular 3x3 ceiling-mounted video wall structure for 42"-47" landscape screens. Built for clean, permanent installations, it delivers high rigidity, seamless height adjustment, and precise tool-less alignment thanks to independent 8-point micro-adjustment.

1. Independent 8-point tool-less micro-adjustment for perfect alignment
2. Seamless height adjustment
3. Screen anti-drop protection (prevents accidental sliding out)
4. Security screws against unauthorised removal



min. 100 x 100
max. 600 x 400



80 kg



42" - 47"

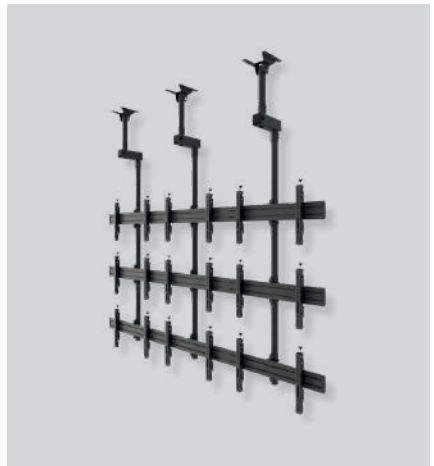

Universal LED Structure



Universal LED Structure

Universal LED Structure is a modular system for creating stable and precisely aligned LED display installations. Designed for professional AV applications, it supports a wide range of cabinet sizes and configurations for both fixed and rental environments. Its versatile design allows the creation of flat, curved, stacked, suspended, freestanding, and custom LED structures.

ULS1250 Universal LED System for 1 cabinet 250 mm

ULS1250 is a modular mounting component from the UniversalLED System, designed for supporting a single LED cabinet with a 250 mm screen size. Engineered for durability, precision, and easy installation, it provides a stable and reliable foundation for professional dvLED video wall structures.

1. Enables precise alignment and stable mounting of dvLED cabinets
2. Supports flat, curved, stacked, and custom LED configurations
3. Lightweight yet durable construction for easy installation
4. RoHS compliant and designed for long-term professional use



ULS1500 Universal LED System for 1 cabinet 500 mm

ULS1500 is a modular mounting component from the UniversalLED System, designed to support a single LED cabinet with a 500 mm screen size. Engineered for durability, precision, and easy installation, it provides a stable and reliable structure for professional dvLED video wall applications.

1. Enables precise alignment and stable mounting of dvLED cabinets
2. Supports flat, curved, stacked, and custom LED configurations
3. Compatible with a wide range of LED cabinet systems



ULS2337 Universal LED System for 2 cabinets 600 x 337,5

ULS2337 is a modular mounting component from the UniversalLED System, designed to support two LED cabinets with a 600 × 337.5 mm screen size. Its lightweight yet durable construction ensures stable mounting, precise alignment, and quick installation.

1. Ensures precise alignment and stable mounting of dvLED cabinets
2. Supports flat, curved, stacked, and custom LED configurations
3. Compatible with a wide range of LED cabinet systems

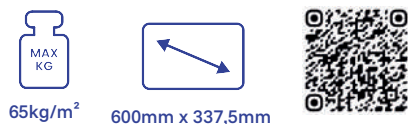

ULS2500 Universal LED System for 2 cabinets 500 mm

ULS2500 is a modular mounting component from the UniversalLED System, designed to support two LED cabinets with a 500 mm screen size. It provides stable mounting, precise alignment, and easy installation for professional dvLED video wall structures.

1. Ensures stable mounting and precise cabinet alignment
2. Supports flat, curved, stacked, and custom LED configurations
3. Lightweight and durable construction for easy installation
4. Suitable for fixed and rental LED installations

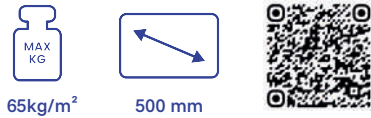

ULS3337 Universal LED System for 3 cabinets 600 x 337,5

ULS3337 is a modular mounting component from the UniversalLED System, designed to support 3 LED cabinets with a 600 × 337.5 mm screen size. It provides stable mounting, precise alignment, and easy installation for professional dvLED video wall structures.

1. Designed for 3 LED cabinets with 600 × 337.5 mm screen size
2. Part of the modular Universal LED System
3. Ensures stable mounting and precise cabinet alignment
4. Supports flat, curved, stacked, and custom LED configurations



ULS4337 Universal LED System for 4 cabinets 600x 337,5

ULS4337 is a modular mounting component from the UniversalLED System, designed to support 4 LED cabinets with a 600 × 337.5 mm screen size. It provides stable mounting, precise alignment, and easy installation for professional dvLED video wall structures.

1. Designed for 4 LED cabinets with 600 × 337.5 mm screen size
2. Part of the modular UniversalLED System
3. Ensures stable mounting and precise cabinet alignment
4. Supports flat, curved, stacked, and custom LED configurations



Projector Mounts



Projector Mounts

Projector Mounts are professional mounting solutions designed to ensure secure, stable, and precise installation of projectors in commercial and public environments. Suitable for offices, conference rooms, classrooms, auditoriums, hospitality venues, and digital signage applications, they help achieve optimal projector positioning for clear and reliable image projection. The range includes versatile ceiling and wall mounting options, offering durability, adjustability, and easy integration into various installation setups.

PMV100 Universal Projector Ceiling Mount



PMV100 is a universal ceiling mount for projectors, designed to provide secure installation, precise positioning, and a clean professional finish. With adjustable tilt, swivel, and height settings, it is suitable for conference rooms, classrooms, offices, and other presentation spaces.

1. 4 fixing points for secure installation Height
2. adjustable from 475 to 650 mm
3. Integrated cable management inside the tube



30 kg



-25°/+25°



-7,5°/+7,5°



PMV200 Universal Projector Ceiling Mount

PMV200 is a universal ceiling mount for projectors, designed for secure installation, precise positioning, and a clean professional appearance. With adjustable tilt, swivel, and extended height range, it is ideal for conference rooms, classrooms, offices, and other presentation spaces.

1. 4 fixing points for secure installation
2. Height adjustable from 650 to 1000 mm
3. Integrated cable management inside the tube

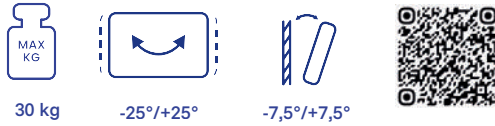

PMV300 Universal Projector Ceiling Mount

PMV300 is a universal ceiling mount for projectors, designed for secure installation, precise positioning, and a clean professional appearance. With adjustable tilt, swivel, and long height adjustment range, it is ideal for conference rooms, classrooms, auditoriums, and other presentation spaces.

1. 4 fixing points for secure installation
2. Height adjustable from 1000 to 1700 mm
3. Integrated cable management inside the tube

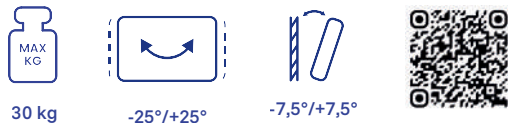

PMV400 Universal Projector Ceiling Mount

PMV400 / PMV400W is a universal ceiling mount for projectors, designed for secure installation, precise positioning, and a compact professional look. Its short drop design makes it ideal for conference rooms, classrooms, offices, and other spaces where minimal distance from the ceiling is required.

1. Available in black (PMV400) and white (PMV400W)
2. 4 fixing points for secure installation
3. Compact design with only 143 mm ceiling drop



Kiosk & Enclosures



Kiosks & Enclosures

Kiosks & Enclosures are professional display solutions designed to protect, support, and present screens in commercial and public environments. Suitable for retail spaces, corporate buildings, transportation hubs, hospitality venues, and self-service applications, they combine durable construction with clean design and practical functionality. The range includes freestanding, wall-mounted, indoor, and dedicated enclosure solutions that help integrate displays securely while enhancing usability, aesthetics, and long-term reliability.



OWM Series

1. OWM90 is an outdoor wall enclosure dedicated to Samsung 46" OH Series monitors. Its compact format makes it a practical solution for smaller outdoor digital signage installations requiring screen protection and clean integration.
2. OWM100 is a robust wall enclosure for Samsung 55" OHF monitors, created for reliable outdoor display protection. Its steel construction, internal ventilation, and easy-access design support safe operation and simple installation.
3. OWM101 is a professional outdoor wall enclosure dedicated to LG 55XE4F-M monitors. It combines durable construction, integrated cable management, and practical service access for secure and long-lasting outdoor use.

POK90 Outdoor Multimedia Kiosk

OWM90 is an outdoor wall enclosure dedicated to Samsung 46" OH Series monitors. Its compact format makes it a practical solution for smaller outdoor digital signage installations requiring screen protection and clean integration.

1. Designed for 1 screen, 46"
2. Durable steel housing for outdoor use
3. Space for additional IT equipment



80 kg



46"



POK100 Outdoor Multimedia Kiosk

POK100 is an outdoor kiosk designed for Samsung 55OHF monitors, offering a larger freestanding solution for outdoor digital signage. Its robust floor-mounted construction ensures stable installation in public spaces, while the clean housing design supports reliable screen protection and easy system integration.

1. Freestanding floor-mounted construction
2. Durable steel housing for outdoor use
3. Optional version with or without logo



80 kg



55"



POK101 Outdoor Multimedia Kiosk

POK101 is an outdoor kiosk developed for LG 55XE4F-M monitors, providing a dedicated freestanding solution for outdoor digital signage. Its floor-mounted design ensures stable installation in public spaces, while the enclosure supports clean integration and reliable long-term outdoor operation.

1. Designed for 1 screen, 55"
2. Freestanding floor-mounted construction
3. Integrated cable management system



80 kg

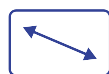

55"





IDS09 series of universal indoor kiosks

IDS09 is a universal indoor freestanding kiosk series designed for 32", 43", 49", 55", and 65" screens. With its simple modern design and durable metal construction, it provides an elegant and practical solution for digital signage, wayfinding, and information display in commercial and public interiors.

MODEL	SCREEN SIZE	Max. Monitor dimensions (WxHxD)	Enclosure dimensions(WxHxD)	Weight	Visible area (WxH)
IDS09.32	32"	435×740×71 mm	580x1825,5x440	56 kg	396×701 mm
IDS09.43	43"	570×980×71 mm	720x1925,5x490	68 kg	535×946 mm
IDS09.49	49"	645×1115×71 mm	780x1925,5x490	71 kg	610×1081 mm
IDS09.55	55"	720×1250×71 mm	850x1925,5x490	74,5 kg	680×1210 mm
IDS09.65	65"	845×1470×71 mm	990x2045,5x490	86 kg	804×1428 mm



IDS10 series of universal indoor kiosks

IDS10 is a series of universal indoor floor-standing kiosks designed for professional digital signage, information points, and self-service applications. Available in screen sizes from 32" to 65", it combines a modern minimalist design, durable construction, and a protective front glass panel for safe and elegant screen integration in commercial and public interiors.

MODEL	SCREEN SIZE	Max. Monitor dimensions(WxHxD)	Enclosure dimensions (WxHxD)	Weight (kg)	Visible area (WxH)
IDS10.32	32"	435×740×71 mm	580×1825×540 mm	63 kg	396×701 mm
IDS10.43	43"	570×980×71 mm	720×1925×540 mm	76 kg	535×946 mm
IDS10.49	49"	645×1115×71 mm	780×1925×540 mm	79 kg	610×1081 mm
IDS10.55	55"	720×1250×71 mm	850×1925×540 mm	82 kg	680×1210 mm
IDS10.65	65"	845×1470×71 mm	990×2045×540 mm	93 kg	804×1428 mm

Retail Mounts



Retail Mounts

Retail Mounts are mounting solutions designed for displays used in retail environments, where clear product communication, visibility, and space efficiency are essential. Suitable for shops, showrooms, service points, and promotional areas, they support professional screen integration while maintaining a clean and functional presentation. The range includes practical mounting options for digital signage, customer information, and in-store communication applications.



Modular POS Systems are flexible mounting solutions designed to create workstation configurations tailored to specific customer and operational needs. Thanks to a wide range of compatible components, the system can be adapted for screens, payment terminals, printers, scanners, keyboards, and other accessories used in retail and service environments. Various mounting options, height adjustment, and integrated cable management allow for ergonomic, space-saving, and professional POS setups. This modular approach makes it easy to build custom configurations for checkout counters, service desks, self-service points, and other customer-facing applications.

PVA50 VESA adapter 75×75, 100×100

PVA50 is a compact VESA adapter for POS monitors, designed to provide convenient screen positioning in sales and service environments. With 2 axes of rotation and compatibility with VESA 75 × 75 and 100 × 100, it is a practical solution for small retail workstations.

- Compact mount for POS monitors
- 2 axes of rotation for convenient screen adjustment
- Compatible with VESA 75 × 75 and 100 × 100
- Durable steel construction



PBP45 Pipe Ø 45mm high with 500 mm desk mounts

PBP45 is a Ø45 mm POS pipe system with 500 mm desk-mounted poles, designed as a stable base for modular POS workstation configurations. It offers full compatibility with POS accessories, integrated cable management, and a choice of mounting methods for clean, functional, and organised checkout or service desk installations.

Available height variants

- PBP45200 – 200 mm
- PBP45350 – 350 mm
- PBP45400 – 400 mm
- PBP45500 – 500 mm



PMC100 Compatible adhesive for PBP series pipes

PMC100 is a countertop clamp mount designed for PBP series POS pipes with a 45 mm diameter. It enables quick and stable installation without drilling, making it a practical solution for flexible POS workstation setups.

- Clamp mount for countertops – no drilling required
- Compatible with Ø45 mm PBP series POS pipes
- Adjustable pressure screws for stable installation
- Durable steel construction with black powder coating
- Quick installation and easy removal



PESA350 Arm adjustable from 280-350mm

PESA350 is an adjustable POS mounting arm with a length range of 280–350 mm, designed for flexible workstation configurations. Compatible with Ø45 mm mounting tubes, it provides stable support for screens, pin pads, POS printers, and other accessories used in retail and service environments.

- Adjustable arm length: 280–350 mm
- Locking mechanism for secure positioning
- Compatible with Ø45 mm mounting tubes
- Suitable for screens, pin pads, POS printers, and accessories
- Durable construction with black finish
- Quick and easy installation



PPS100 Printer shelf 180×150, Ø 36mm

PPS100 is a printer shelf designed for POS and kiosk installations, with a platform size of 180 × 150 mm. Intended for mounting on Ø36 mm posts, it provides stable support for receipt printers in retail and customer service environments.

- Printer shelf size: 180 × 150 mm
- Designed for mounting on Ø36 mm posts
- Durable steel construction
- Black finish for a clean professional look
- Quick and easy installation
- Suitable for POS systems and information kiosks



Window Display Mounts



Window Display Mounts

Window Display Mounts are mounting solutions designed for screens installed in shop windows and storefront environments, where visibility, clean presentation, and effective use of space are essential. They enable secure and elegant screen integration for advertising, promotions, and customer communication while maintaining a modern retail appearance. Suitable for a wide range of commercial applications, these systems help create eye-catching window displays that attract attention and support in-store marketing.

MWDC Window Facing Display Mounts

MWDC is a ceiling-mounted solution for storefront digital displays, designed for Samsung OMN 46"–55" screens. It provides a clean and professional way to integrate window-facing displays while saving floor space and maintaining a modern retail appearance.

- Ceiling mount for Samsung OMN 46"–55" displays
- Designed for storefront and shop window installations
- Ceiling-mounted construction for a clean presentation
- Integrated cable routing
- Durable and secure design
- Black finish for a neutral, professional look
- Maximum load capacity: 50 kg
- Also available in floor-mounted and floor-to-ceiling variants



MWDF Floor-Mounted Window-Facing Display

MWDF is a floor-mounted stand designed for Samsung OMN 46"–55" displays, including the Samsung 55OMN-D monitor. It provides a stable and elegant solution for shop window installations, with integrated cable routing for a clean and professional appearance.

- Floor stand for Samsung OMN 46"–55" displays
- Compatible with Samsung 55OMN-D monitor
- Designed for storefront and shop window installations
- Floor-mounted construction for high stability
- Integrated cable routing system
- Quick and easy installation
- Modern black finish
- Maximum load capacity: 50 kg
- Also available in ceiling-mounted and ceiling-to-floor variants



MWDFC Floor and ceiling mounting bracket for store windows

MWDFC is a floor-to-ceiling mounting solution for storefront digital displays, designed for Samsung OMN 46"–55" screens. It offers a stable and elegant way to integrate window-facing displays, combining clean cable routing with a modern, space-efficient design.

- Floor-to-ceiling mount for Samsung OMN 46"–55" displays
- Designed for storefront and shop window installations
- Stable floor-and-ceiling mounted construction
- Integrated cable management system
- Modern black finish
- Quick and easy installation
- Maximum load capacity: 50 kg
- Suitable for boutiques, chain stores, and shopping mall showcases



ITSV03 Stand for 10-29" screen

ITSV03 is a freestanding stand designed for 10"–29" screens and tablets, ideal for reception areas, customer service points, and multimedia presentations. Its stable base, integrated cable management, and slight tilt adjustment ensure a clean, secure, and professional display setup.

- Freestanding stand for 10"–29" screens and tablets
- Compatible with VESA 75 × 75 to 100 × 100
- Stable base for safe installation
- Tilt adjustment: +8°
- Integrated cable management inside the structure
- Dedicated mounting adapter included
- Suitable for reception areas, customer service points, and multimedia presentations
- Black finish
- 5-year warranty





Vertical Markets

EDBAK mounting and display solutions are developed for a broad range of vertical markets, helping businesses and institutions create effective, durable, and visually consistent AV installations. Our systems support applications in retail, corporate offices, education, hospitality, transportation, healthcare, public spaces, and many other professional environments.

Whether the goal is customer engagement, information display, wayfinding, collaboration, or self-service, EDBAK provides solutions adapted to the specific requirements of each sector.

Our projects

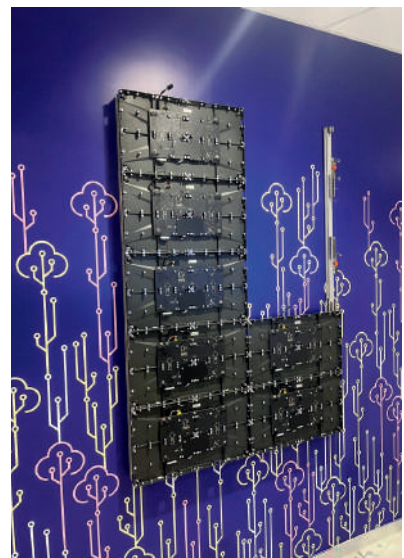
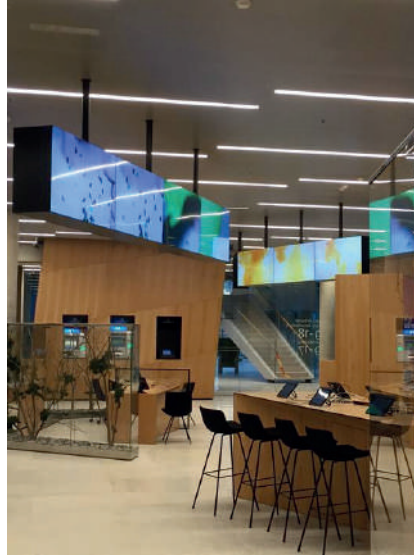

Our projects

Every installation tells a different story. This selection of projects shows how EDBAK solutions perform in real environments, combining reliable construction, clean design, and installation flexibility. From single-display setups to complex multi-screen structures, our systems help turn technical requirements into functional, well-integrated AV spaces. Each implementation reflects a practical response to the needs of the location, the technology, and the end user. It also demonstrates our ability to support partners in delivering installations that are both visually consistent and built for everyday performance.



EDBAK

EDBAK Sp. z o.o.
Piotrowice 186
23-107 Strzyżewice
Poland
tel. +48 81 562 81 19
www.edbak.com
sales@edbak.com

